

TOSHIBA

Leading Innovation >>>

Integrated High Definition LED Television Resource Guide

58L7350U 65L7350U

NOTE Keep this Resource Guide in a convenient place to access important information about your television. To obtain additional information, consult the comprehensive electronic User's Guide at support.toshiba.com.

If you need assistance:
 ❖ Toshiba's Support Web site
 support.toshiba.com

Owner's Record

The model number and serial number are on the back and side of your television. Record these numbers, whenever you communicate with your Toshiba dealer about this Television.

Model name _____

Serial number _____

Register your Toshiba Television at register.toshiba.com.

Note: To display a High Definition picture, the TV must be receiving a High Definition signal (such as an over-the-air High Definition TV broadcast, a High Definition digital cable program, or a High Definition digital satellite program). For details, contact your TV antenna installer, cable provider, or satellite provider.

Dear Customer,
 Thank you for purchasing this Toshiba LED TV. This document will help you use the many exciting features of your new LED TV. Before operating your LED TV, carefully read this document completely.

Safety Precautions
WARNING: TO REDUCE THE RISK OF FIRE OR ELECTRIC SHOCK, DO NOT EXPOSE THIS APPLIANCE TO RAIN OR MOISTURE.



WARNING: TO REDUCE THE RISK OF ELECTRIC SHOCK, DO NOT REMOVE COVER (OR BACK). NO USER-SERVICEABLE PARTS INSIDE. REFER SERVICE TO QUALIFIED SERVICE PERSONNEL.

The lightning flash with arrowhead symbol, within an equilateral triangle, is intended to alert the user to the presence of uninsulated "dangerous voltage" within the product's enclosure that may be of sufficient magnitude to constitute a risk of electric shock to persons.

The exclamation point within an equilateral triangle is intended to alert the user to the presence of important operating and maintenance (servicing) instructions in the literature accompanying the appliance.

WARNING To prevent injury, this apparatus must be securely attached to the floor/wall in accordance with the installation instructions. See instructions on item 26).

WARNING: If you decide to wall mount this television, always use a mounting bracket that has been Listed by an independent laboratory (such as UL, CSA, ETL) and is appropriate for the size and weight of this television. The use of inappropriate or non-Listed mounting brackets could result in serious bodily injury and/or property damage. See "To Display your LED TV using a Wall Bracket:" below.

CHILD SAFETY: PROPER TELEVISION PLACEMENT MATTERS

TOSHIBA CARES:

Manufacturers, retailers and the rest of the consumer electronics industry are committed to making home entertainment safe and enjoyable.
 As you enjoy your television, please note that all televisions – new and old – must be supported on proper stands or installed according to the manufacturer's recommendations. Televisions that are inappropriately situated on dressers, bookcases, shelves, desks, speakers, chests, carts, etc., may fall over, resulting in injury.

TUNE IN TO SAFETY

ALWAYS follow the manufacturer's recommendations for the safe installation of your television.
ALWAYS read and follow all instructions for proper use of your television.
NEVER allow children to climb on or play on the television or the furniture on which the television is placed.
NEVER place the television on furniture that can easily be used as steps, such as a chest of drawers.
ALWAYS install the television where it cannot be pushed, pulled over or knocked down.
ALWAYS route cords and cables connected to the television so that they cannot be tripped over, pulled or grabbed.
WALL OR CEILING MOUNT YOUR TELEVISION
ALWAYS contact your retailer about professional installation if you have any

doubts about your ability to safely mount your television.

ALWAYS use a mount that has been recommended by the television manufacturer and has a safety certification by an independent laboratory (such as UL, CSA, ETL).
ALWAYS follow all instructions supplied by the television and mount manufacturers.
ALWAYS make sure that the wall or ceiling where you are mounting the television is appropriate.
 Some mounts are not designed to be mounted to walls and ceilings with steel studs or cinder block construction. If you are unsure, contact a professional installer.
 Televisions can be heavy. A minimum of two people is required for a wall or ceiling mount installation.

MOVING AN OLDER TELEVISION TO A NEW PLACE IN YOUR HOME

Many new television buyers move their older CRT televisions into a secondary room after the purchase of a flat-panel television. Special care should be made in the placement of older CRT televisions.
ALWAYS place your older CRT television on furniture that is sturdy and appropriate for its size and weight.
NEVER place your older CRT television on a dresser where children may be tempted to use the drawers to climb.
ALWAYS make sure your older CRT television does not hang over the edge of your furniture.



NOTE TO CATV INSTALLERS

This is a reminder to call the CATV system installer's attention to Article 820-40 of the U.S. NEC, which provides guidelines for proper grounding and, in particular, specifies that the cable ground shall be connected to the grounding

system of the building, as close to the point of cable entry as practical. For additional antenna grounding information, see items 33) and 34).

Important Safety Instructions

- 1) Read these instructions.
- 2) Keep these instructions.
- 3) Heed all warnings.
- 4) Follow all instructions.
- 5) Do not use this apparatus near water.
- 6) Clean only with dry cloth.
- 7) Do not block any ventilation openings. Install in accordance with the manufacturer's instructions.
- 8) Do not install near any heat sources such as radiators, heat registers, stoves, or other products (including amplifiers) that produce heat.
- 9) Do not defeat the safety purpose of the polarized or grounding type plug. A polarized plug has two blades with one wider than the other. A grounding type plug has two blades and a third grounding prong. The wide blade or the third prong are provided for your safety. If the provided plug does not fit into your outlet, consult an electrician for replacement of the obsolete outlet.
- 10) Protect the power cord from being walked on or pinched, particularly at plugs, convenience receptacles, and the point where they exit from the apparatus.
- 11) Only use attachments/accessories specified by the manufacturer.
- 12) Use only with the cart, stand, tripod, bracket, or table specified by the manufacturer, or sold with the apparatus. When a cart is used, use caution when moving the cart/apparatus combination to avoid injury from tip-over.
- 13) Unplug this apparatus during lightning storms or when unused for long periods of time.

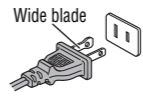

- 14) Refer all servicing to qualified service personnel. Servicing is required when the apparatus has been damaged in any way, such as power-supply cord or plug is damaged, liquid has been spilled or objects have fallen into the apparatus, the apparatus has been exposed to rain or moisture, does not operate normally, or has been dropped.

Additional Safety Precautions

- 14a) **CAUTION:** If the TV is dropped and the cabinet or enclosure surface has been damaged or the TV does not operate normally, take the following precautions:
 - ALWAYS turn off the TV and unplug the power cord to avoid possible electric shock or fire.
 - NEVER allow your body to come in contact with any broken glass or liquid from the damaged television. The LCD panel inside the TV contains glass and a toxic liquid. If the liquid comes in contact with your mouth or eyes, or your skin is cut by broken glass, rinse the affected area thoroughly with water and contact your doctor immediately.
 - ALWAYS contact a service technician to inspect the TV any time it has been damaged or dropped.
- 15) **CAUTION:**
 - To reduce the risk of electric shock, do not use the polarized plug with an extension cord, receptacle, or other outlet unless the blades can be inserted completely to prevent blade exposure.
 - To prevent electric shock, match wide blade of plug to wide slot; fully insert.
- 16) **CAUTION:** Do not let children swallow any small parts included on or with the product or play with the plastic bag. Keep the small parts and the plastic bag out of the reach of children.

- 17) **CAUTION:** Do not let water or other liquids come into contact with the product, as it may result in damage.
- 18) **WARNING:**
 - To prevent the spread of fire, keep candles or other open flames away from this product at all times.
 - Keep the product away from direct sunlight, fire or a heat source such as a heater. This may reduce the product lifetime or result in fire.

Installation, Care, and Service

- Follow these recommendations and precautions and heed all warnings when installing your TV:
- 19) **WARNING: NEVER expose batteries to excessive heat such as sunshine, fire, or the like.**
 - 20) ALWAYS plug the product into an outlet that is located in such a manner that it can be easily unplugged in case the product requires service.
 - 21) NEVER route the product's power cord inside a wall or similar enclosed area.
 - 22) Never modify this equipment. Changes or modifications may void: a) the warranty, and b) the user's authority to operate this equipment under the rules of the Federal Communications Commission.
 - 23) **DANGER: RISK OF SERIOUS PERSONAL INJURY, DEATH, OR EQUIPMENT DAMAGE**
 Never place the TV on an unstable cart, stand, or table. The TV may fall, causing serious personal injury, death, or serious damage to the TV.

- 24) When selecting a location for the TV,
 - NEVER allow any part of the TV to hang over the edge of the supporting furniture,
 - NEVER place the TV on tall furniture (for example, entertainment centers or bookcases) without anchoring both the furniture and the TV to a suitable support,
 - Never place cloth or other material between the TV and the supporting furniture.
 - NEVER allow children to climb on the TV.
- 25) To avoid damage to this product, never place or store the TV in direct sunlight; hot, humid areas; or areas subject to excessive dust or vibration.
- 26) Always place the TV on the floor or a sturdy, level, stable surface that can support the weight of the unit. Secure the TV using one of the following methods:
 - (1) Secure the TV with a mounting screw (Recommended.)
 - Place the TV on a sturdy surface that has a sufficient thickness and screw the unit on the surface securely by using the mounting screw and the fall-prevention screw hole.

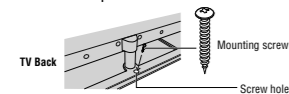

- (2) Secure the TV with a sturdy strap to a wall stud, pillar, or other immovable structure. When connecting the strap:
 - attach the strap to the TV using the hooks on the back of the TV, the clips on the pedestal, or the hole in the base of the pedestal as available.
 - make sure the strap is tight, secure, and parallel to the floor.

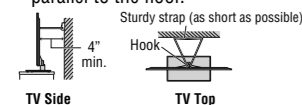

- 27) The apparatus shall not be exposed to dripping or splashing, and that no objects filled with

- liquids, such as vases, shall be placed on the apparatus.
- 28) Never block or cover the slots or openings in the TV cabinet back, bottom, and sides. Never place the TV:
 - on a bed, sofa, rug, or similar surface;
 - too close to drapes, curtains, or walls; or
 - in a confined space such as a bookcase, built-in cabinet, or any other place with poor ventilation.
- 29) Always leave a space of at least 4 (four) inches around the TV. The slots and openings are provided to protect the TV from overheating and to help maintain reliable operation of the TV.
- 30) Never allow anything to rest on or roll over the power cord, and never place the TV where the power cord is subject to wear or abuse.
- 31) Never overload wall outlets and extension cords.
- 32) Always operate this equipment from a 120V AC, 60 Hz power source.
- 33) Always make sure the antenna system is properly grounded to provide adequate protection against voltage surges and built-up static charges (see Section 810 of the National Electric Code).

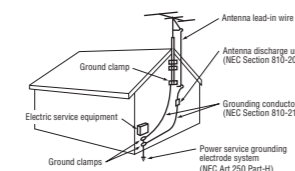

DANGER: RISK OF SERIOUS PERSONAL INJURY OR DEATH!

- Use extreme care to make sure you are never in a position where your body (or any item you are in contact with, such as a ladder or screwdriver) can accidentally touch overhead power lines.

Never locate the antenna near overhead power lines or other electrical circuits.
 • Never attempt to install any of the following during lightning activity: a) an antenna system; or b) cables, wires, or any home theater component connected to an antenna or phone system.

Care

For better performance and safer operation of your TOSHIBA TV, follow these recommendations and precautions:

- 35) If you use the TV in a room whose temperature is 32° F (0° C) or below, the picture brightness may vary until the LCD warms up. This is not a sign of malfunction.

WARNING: RISK OF SERIOUS PERSONAL INJURY OR EQUIPMENT DAMAGE!

- Never use chemicals (such as air fresheners, cleaning agents, etc.) on or near the TV pedestal. Studies indicate that plastics may weaken and crack over time from the combined effects of chemical agents and mechanical stress (such as the weight of the TV). Failure to follow these instructions could result in serious injury and/or permanent damage to TV and TV pedestal.
- Always unplug the TV before cleaning. Gently wipe the display panel surface (the TV screen) using a dry, soft cloth (cotton, flannel, etc.). A hard cloth may damage the surface of the panel.
- Avoid contact with alcohol, thinner, benzene, acidic or alkaline solvent cleaners, abrasive cleaners, or chemical cloths, which may damage the surface. Never spray volatile compounds such as insecticide on the cabinet. Such products may damage or discolor the cabinet.

- 37) Never hit, press, or place anything on the back cover. These actions will damage internal parts.

WARNING: RISK OF ELECTRIC SHOCK!

Never spill liquids or push objects of any kind into the TV cabinet slots.

- 38) During a lightning storm, do not touch the connecting cables or product.
- 39) For added protection of your TV from lightning and power surges, always unplug the power cord and disconnect the antenna from the TV if you leave the TV unattended or unused for long periods of time.
- 40) Always unplug the TV to completely disconnect from mains power. When the TV is turned off using the on/off switch, it is not completely disconnected from power and a minute amount of current is still consumed.
- 41) During normal use, the TV may make occasional snapping or popping sounds. This is normal, especially when the unit is being turned on or off. If these sounds become frequent or continuous, unplug the power cord and contact a Toshiba Authorized Service Provider.
- 42) **WARNING: RISK OF SERIOUS PERSONAL INJURY OR EQUIPMENT DAMAGE!**
 Never strike the screen with a sharp or heavy object.
- 43) The LCD screen of this product can be damaged by ultraviolet radiation from the sun. When selecting a location for the television, avoid locations where the screen may be exposed to direct sunlight, such as in front of a window.
- 44) Never touch, press, or place anything on the LCD screen. These actions will damage the LCD screen. If you need to clean the LCD screen follow the instructions (in item 36).

Service

WARNING: RISK OF ELECTRIC SHOCK!

- 45) Never attempt to service the TV yourself. Opening and removing the covers may expose you to dangerous voltage or other hazards. Failure to follow this WARNING may result in death or serious injury. Refer all servicing not specified in this manual to a Toshiba Authorized Service Provider.
- 46) If you have the TV serviced:
 - Ask the service technician to use only replacement parts specified by the manufacturer.
 - Upon completion of service, ask the service technician to perform routine safety checks to determine that the TV is in safe operating condition.

Choosing a location for your LED TV

To Display your LCD TV on the included Pedestal Stand:

- 1) Observe the following safety precautions:
 - 1) Read and follow the pedestal assembly instructions included with the pedestal.
- CAUTION:** Before beginning pedestal assembly, carefully lay the front of the LCD Panel face down on a flat, cushioned surface such as a quilt or blanket. Leave the bottom of the unit protruding over the edge of the surface and assemble the pedestal as indicated below.

Note: Extreme care should always be used when attaching the pedestal stand to avoid damage to the LCD panel.

- 2) Place the TV on a sturdy, level surface that can support the weight of the TV.
- 3) Be sure to secure the TV to a wall, pillar, surface, or other immovable structure see item 26) for additional details.

To Display your LED TV using a Wall Bracket:

If you decide to wall mount your LED TV, always use a wall bracket Listed by an independent laboratory (such as UL, CSA, ETL) that is appropriate for the size and weight of the TV:

- 1) **CAUTION:** Two people are required for installation.
- 2) Unplug and remove any cables and/or other component connectors from the rear of the TV.
- 3) Remove the screws of the VESA Mounting Pattern show in the table below, if applicable.

CAUTION: Do not use the screws removed from the back cover to attach the wall mount bracket to the TV.

- 4) Always use the screws supplied or recommended by the wall mount manufacturer.
- 5) Follow the instructions provided with your wall bracket. Before proceeding, make sure the appropriate bracket(s) are attached to the wall and the back of the TV as described in the instructions provided with the wall bracket.
- 6) After attaching the appropriate bracket(s) to the wall and the back of the TV, remove the pedestal stand from the TV, as described below.
- 7) VESA Mounting Pattern

| TV Size | Hole Pattern (HxV) | Screw Size |
|----------|--------------------|------------|
| 58L7350U | 400x400 mm | M6 |
| 65L7350U | 400x400 mm | M6 |

(unit in mm)

Removing the Pedestal Stand

- 1) Carefully lay the front of the unit face down on a flat, cushioned surface such as a quilt or blanket. Leave the stand protruding over the edge of the surface.
- 2) **Note:** Extreme care should always be used when removing the pedestal stand to avoid damage to the LCD panel.
- 3) Remove the stand screws shown in the diagram below. This will allow removal of the pedestal stand.

Once you have removed all of the screws holding the pedestal stand in place, remove the pedestal stand from the TV.

CAUTION: Always place the TV on the floor or a sturdy, level, stable surface that can support the weight of the unit. Secure the TV as described in item 26) of the Important Safety Instructions in this document.

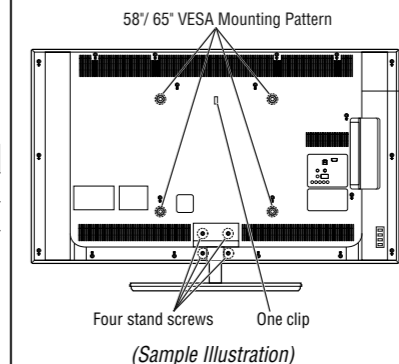

Four stand screws One clip (Sample Illustration)

Safety Precautions for 3D glasses

Available 3D glasses :
 Toshiba FPT-AG03 (Supplied)

WARNING: DO NOT INGEST BATTERY. CHEMICAL BURN HAZARD

- This product contains a coin/button cell battery. If the coin/button cell battery is swallowed, it can cause severe internal burns in just 2 hours and can lead to death.
- Keep new and used batteries away from children. If the battery compartment does not close securely, stop using the product and keep it away from children.
- If you think batteries might have been swallowed or placed inside any part of the body, seek immediate medical attention.

About handling the 3D glasses

- Do not leave the 3D glasses or the accessories within the reach of small children.
- Inhaling or swallowing them may cause suffocation or lesions in the stomach wall. If swallowed, consult a doctor immediately.
- Do not repair, modify, or disassemble the 3D glasses by yourself.
- Contact the Toshiba Call Center for repair of your 3D glasses.
- Do not expose the glasses to excessive heat for example sunshine or fire.

Caution

- About the 3D glasses
- Do not use the 3D glasses if they are cracked, broken, or not working properly. Continuing to use them in such a state may cause injury, eye strain, or minor discomfort.
 - Do not stand or walk while wearing 3D glasses.



GMA501159011 2/13

- You may lose your balance which could result in falls or other accidents.
- Do not wear the 3D glasses for any purpose other than viewing 3D programming. 3D glasses do not function as sunglasses.
 - Do not drop, exert pressure on, or step on the 3D glasses. Doing so may damage the glass section, which may result in injury. Exposing the 3D glasses to liquid or excessive heat may damage the liquid crystal shutter function.
 - If your nose or temple turns red, or you feel any pain or discomfort, stop using the 3D glasses. Such symptoms may occur when wearing 3D glasses for long periods of time.
 - Be careful not to pinch your fingers in the hinge of the 3D glasses.

Cautions on watching the 3D images

- Some viewers may experience a seizure or blackout when exposed to certain flashing images or lights contained in certain 3D television pictures or video games. Anyone who has had a seizure, loss of awareness, or other symptoms linked to an epileptic condition, or has a family history of epilepsy, should contact a health care provider before using the 3D function.
- Avoid using the 3D function when under the influence of alcohol.
- If you are ill or feel ill, you should refrain from viewing 3D images, and consult your health care provider as may be appropriate.
- If you experience any of the following symptoms when viewing 3D video images, stop viewing and contact your health care provider:
 - Convulsions, eye or muscle twitching, loss of awareness, altered vision, involuntary movements, disorientation, eye strain, nausea/vomiting, dizziness, headaches.
- If you feel eye fatigue or other discomfort from viewing 3D video images, remove the 3D glasses and discontinue use until the

- condition is eliminated.
- Viewing in 3D may cause dizziness and/or disorientation for some viewers. Therefore, to avoid injury do not place your TV near open stairwells, balconies, or wires. Also do not sit near objects that could be broken if accidentally hit.
 - When viewing 3D images, always wear 3D glasses. Watching 3D images without 3D glasses may cause eye strain. Use specified 3D glasses.
 - When watching 3D images, do not wear 3D glasses at an angle and do not lie down. If you watch while lying down or with the glasses tilted, the 3D effect is lost and it may cause eye strain.
 - It is recommended that the viewer's eyes and 3D glasses are level with the screen.
 - If you have prescription eye glasses or contact lenses, wear the 3D glasses over them. Watching 3D images without appropriate eyewear may cause eye strain.
 - If 3D images often appear in double or if you cannot see the images in 3D, stop viewing. Continuous viewing may cause eye strain.
 - Due to the possible impact on vision development, viewers of 3D video images should be age 6 or above. Children and teenagers may be more susceptible to health issues associated with viewing in 3D and should be closely supervised to avoid prolonged viewing without rest.
 - Watching TV while sitting too close to the screen for an extended period of time may cause eye strain. The ideal viewing distance should be at least three times the screen height.

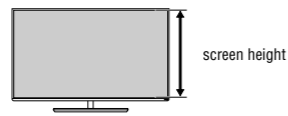

- Use the 3D glasses in the following viewing angle. Otherwise, you may not see the correct 3D image. Effective viewing angle:
 - Within 30° horizontal, 20° vertical

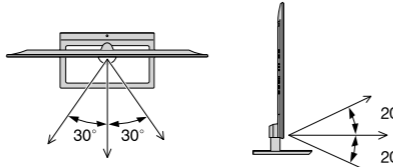

Notes on handling the 3D glasses:

- When cleaning the 3D glasses, gently wipe with a dry, soft cloth.
 - First, remove any dirt or dust from the 3D glasses.
 - Harsh rubbing or use of a dirty or coarse cloth will scratch the 3D glasses.
- Do not use benzene, paint thinner, alcohol, water, or abrasive cleaners, which may damage the 3D glasses.
- Do not store the 3D glasses in areas of extreme heat or cold, as deformation can occur. If deformation occurs, replace the 3D glasses.
- The lenses of the 3D glasses are different from those of ordinary glasses, and are very thin. Be very careful in handling the 3D glasses as the lens can pop out easily. Do not put excessive force on the lenses.
- Do not scratch the surface of the lenses with sharp objects.
- Do not drop or bend the 3D glasses.

Notes on IR communication:

- Do not block the IR sensor for 3D glasses on the TV by placing objects in front of it.
- Do not cover the IR sensor on the 3D glasses with stickers or labels.
- Keep the IR sensor on the 3D glasses clean.
- The use of 3D glasses could interfere with

other IR communication devices. Other IR communication devices may cause the 3D glasses not to work correctly. Use the TV and 3D glasses in a place where they will not interfere with other devices or products.

Notes on watching the TV:

- Proper 3D effects or 3D-to-2D conversion results may not be obtained depending on the received 3D content.
- 3D effect and image quality may vary depending upon content quality and display device capability/functionality/settings.
- If you use any device, such as a mobile phone or mobile wireless device, near the 3D glasses, the 3D glasses may not work correctly.
- If there is fluorescent lighting in the viewing area, it may flicker depending on the frequency of the light. In this case, reduce the brightness of the fluorescent light, or use another light. (It is not recommended to watch the TV in a dark room, especially for children.)
- Wear the 3D glasses properly, otherwise you may not see the correct 3D images.
- When not viewing 3D images, take off the 3D glasses; otherwise, it may be difficult to see the display on other products such as PC, digital clock, or calculator, etc.
- The 2D to 3D conversion function is activated and controlled by you according to your personal preferences.
- The 2D to 3D conversion function is meant for enjoyment of 2D home video, and other 2D content you create, in 3D according to your personal preferences.
- The 2D to 3D conversion function is not intended for use with pre-recorded 2D copyrighted content owned by a third-party unless the copyright owner has given direct or indirect permission, or unless applicable law permits such use.

FCC Caution

To assure continued compliance, follow the attached installation instructions. Any changes or modifications not expressly approved by Toshiba America Information Systems, Inc. could void the user's authority to operate this device. Service Center or an experienced radio/TV technician for help.

FCC Declaration of Conformity Compliance Statement (Part 15):

Toshiba television models 58L7350U and 65L7350U comply with Part 15 of the FCC Rules. Operation is subject to the following two conditions:

- (1) This device may not cause harmful interference, and
- (2) This device must accept any interference received, including interference that may cause undesired operation.

The party responsible for compliance to these rules is:

Toshiba America Information Systems, Inc.
9740 Irvine Blvd., Irvine, CA 92618.
Phone: 800-631-3811

Note: This equipment has been tested and found to comply with the limits for a Class B digital device, pursuant to Part 15 of the FCC Rules. These limits are designed to provide reasonable protection against harmful interference in a residential installation. This equipment generates, uses, and can radiate radio frequency energy and, if not installed and used in accordance with the instructions, may cause harmful interference to radio communications. However, there is no guarantee that interference will not occur in a particular installation. If this equipment does cause harmful interference to radio or television reception, which can be determined by removing and applying power to the equipment, the user is encouraged to try to correct the interference by one of the following measures:

- Reorient or relocate the receiving antenna.

- Increase the separation between the equipment and receiver.
- Connect the equipment into an outlet on a circuit different from that to which the receiver is connected.
- Consult the dealer or an experienced radio/TV technician for help.

Caution: Changes or modifications to this equipment not expressly approved by Toshiba could void the user's authority to operate this equipment.

ENERGY STAR® User Information

ENERGY STAR User Information Statement: the factory default settings of this television meet ENERGY STAR requirements. Changing Picture Settings may increase energy consumption, possibly beyond the limits required for ENERGY STAR qualification. To ensure your television is operating at optimal energy efficiency, select [Home] mode during initial activation. To return to [Home] mode settings, select [Standard] picture mode. [Standard] mode is recommended for normal home use.



ENERGY STAR® qualified TV.

Products that earn the ENERGY STAR prevent green house gas emissions by meeting strict guidelines set by the U.S. Environmental Protection Agency. ENERGY STAR and the ENERGY STAR mark are registered U.S. marks.

Important notes about your TV

The following symptoms are technical limitations of LCD Display technology and are not an indication of malfunction; therefore, Toshiba is not responsible for perceived issues resulting from these symptoms.

- An afterimage (ghost) may appear on the screen if a fixed, non-moving image appears for a long period of time. The afterimage is not permanent and will disappear in a short period of time.

- The LCD panel contained in this TV is manufactured using an extremely high level of precision technology; however, there may be an occasional pixel (dot of light) that does not operate properly (does not light, remains constantly lit, etc.). This is a structural property of LCD technology, is not a sign of malfunction, and is not covered under your warranty. Such pixels are not visible when the picture is viewed from a normal viewing distance.

Note: Interactive video games that involve shooting a "gun" type of joystick at an on-screen target may not work with this TV.

Trademark Information

- ColorStream is a registered trademark of Toshiba America Information Systems, Inc. and/or Toshiba Corporation.
- HDMI, the HDMI Logo, and High-Definition Multimedia Interface are trademarks or registered trademarks of HDMI Licensing LLC in the United States and other countries. [Standard] mode is recommended for normal home use.
- Netflix is a registered trademark of Netflix, Inc.
- All other brand and product names are trademarks or registered trademarks of their respective companies.

Copyright

This guide is copyrighted by Toshiba America Information Systems, Inc. with all rights reserved. Under the copyright laws, this guide cannot be reproduced in any form without the prior written permission of Toshiba. No patent liability is assumed, however, with respect to the use of the information contained herein. ©2013 by Toshiba America Information Systems, Inc. All rights reserved.

Notice

The information contained in this manual, including but not limited to any product specifications, is subject to change without notice.

TOSHIBA CORPORATION AND TOSHIBA AMERICA INFORMATION SYSTEMS, INC. (TOSHIBA) PROVIDES NO WARRANTY WITH REGARD TO THIS MANUAL OR ANY OTHER INFORMATION CONTAINED HEREIN AND HEREBY EXPRESSLY DISCLAIMS ANY IMPLIED WARRANTIES OF MERCHANTABILITY OR FITNESS FOR ANY PARTICULAR PURPOSE WITH REGARD TO ANY OF THE FOREGOING. TOSHIBA ASSUMES NO LIABILITY FOR ANY DAMAGES INCURRED DIRECTLY OR INDIRECTLY FROM ANY TECHNICAL OR TYPOGRAPHICAL ERRORS OR OMISSIONS CONTAINED HEREIN OR FOR DISCREPANCIES BETWEEN THE PRODUCT AND THE MANUAL. IN NO EVENT SHALL TOSHIBA BE LIABLE FOR ANY INCIDENTAL, CONSEQUENTIAL, SPECIAL, OR EXEMPLARY DAMAGES, WHETHER BASED ON TORT, CONTRACT OR OTHERWISE, ARISING OUT OF OR IN CONNECTION WITH THIS MANUAL OR ANY OTHER INFORMATION CONTAINED HEREIN OR THE USE THEREOF.

Troubleshooting

Refer to the "Troubleshooting" chapter in the online User's Guide at support.toshiba.com. If you are still having trouble you may need to contact Toshiba for additional assistance.

Toshiba Support

If you require help or are having problems operating your product, contact Toshiba at Toshiba's Support Web site: support.toshiba.com.

Connecting your TV

For detailed information, see the "Connecting your TV" section in the User's Guide located at support.toshiba.com.

Connecting an HDMI™ or DVI device to the HDMI™ input

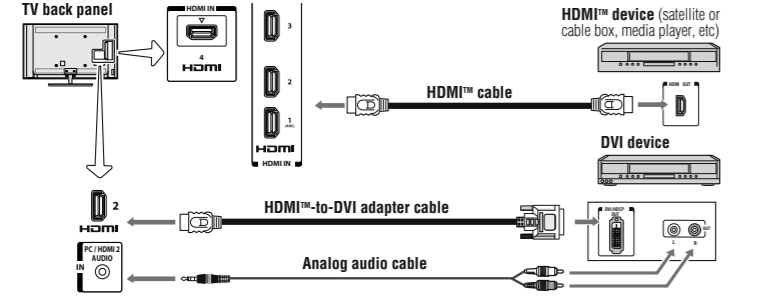

(Sample Illustration) HDMI™ and DVI connections

Connecting an HDMI™ CEC Device

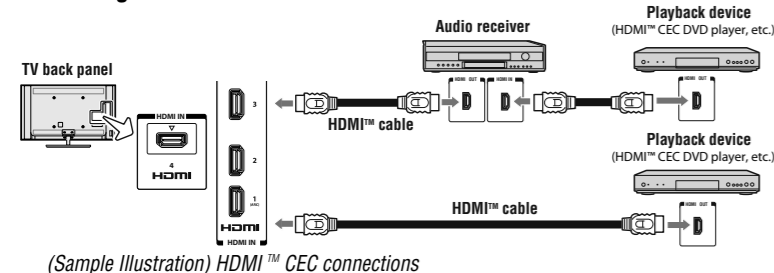

(Sample Illustration) HDMI™ CEC connections

Connecting a digital audio system

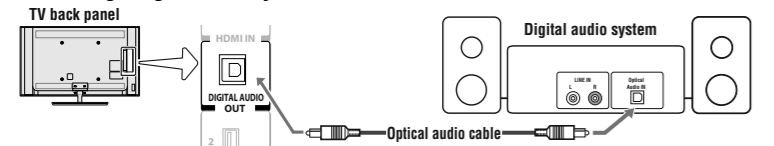

(Sample Illustration) Connecting a digital audio system

Connecting an antenna, satellite receiver, and cable TV box

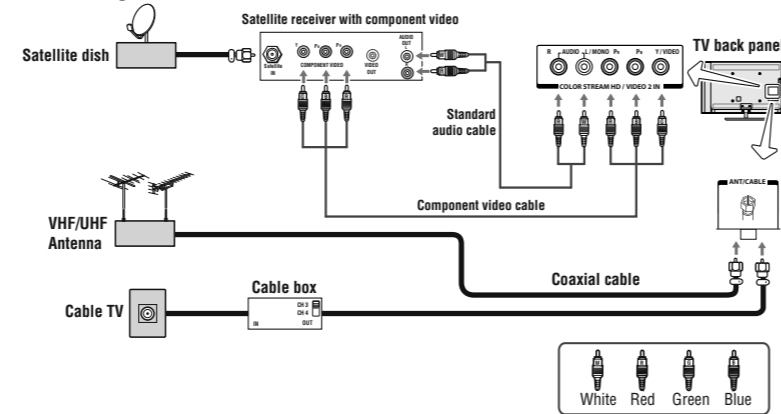

(Sample Illustration) Connecting to an antenna, satellite receiver, and cable TV box.

Connecting a DVD player with ColorStream® or a VCR with composite video

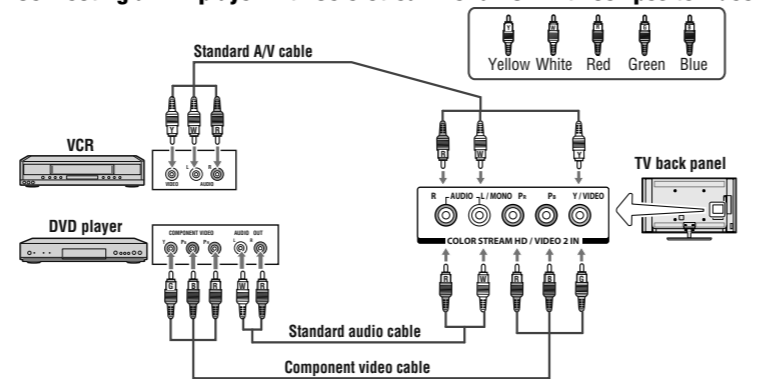

(Sample Illustration) Connecting a DVD player with ColorStream® or a VCR with composite video.

Using the Remote

The buttons used for operating the TV are described here. For the HDMI™ CEC remote control functions, see the "HDMI™ CEC playback device (DVD player, etc.) control" section in the User's Guide.

NOTE

The error message "NOT AVAILABLE" may appear if you press a key for a function that is not available.

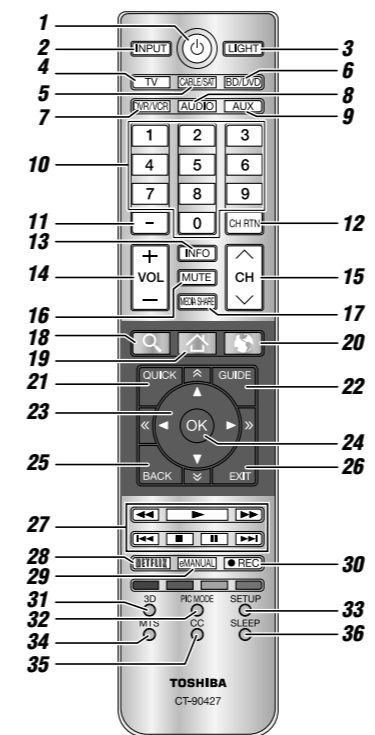

(Sample Illustration) Remote control overview

For detailed information, see the "Using the Remote Control" section in the User's Guide located at support.toshiba.com.

| Item: | Description: | Function: | Item: | Description: | Function: |
|-------|------------------------------|---|-------|------------------------------|---|
| 1 | POWER button | Turns the TV On and Off. When the TV is on, the power LED indicator on the front of the TV glows green. | 21 | QUICK button | Launches the Quick menu. |
| 2 | INPUT button | Selects the video input source. | 22 | GUIDE button | Launches the MediaGuide application on-screen. |
| 3 | Light button | Illuminates the keypad for five seconds. | 23 | (▲/▼/◀/▶) | Selects or adjusts programming buttons menus when a menu is on-screen. |
| 4 | TV button | | | (↶/↷/◀◀/▶▶) | Scrolls the page up, down, left, and right. |
| 5 | Cable/Satellite button | Sets the remote control mode to control the device: TV, CABLE/SAT, BD/DVD, DVR/VCR, AUDIO, or AUX. | 24 | OK button | Selects the highlighted items on the screen. |
| 6 | BD/DVD button | | 25 | BACK button | Returns to the previous screen. |
| 7 | DVR/VCR button | | 26 | EXIT button | Closes on-screen menus. |
| 8 | Audio button | | 27 | (▶/◀◀/▶▶/◀▶/▶▶) | ▶ : PLAY button ◀◀ : REWIND button ▶▶ : FAST FORWARD button ◀▶ : SKIP-BACK button ▶▶ : SKIP-FORWARD button ■ : STOP button ⏸ : PAUSE button |
| 9 | Auxiliary button | | 10 | Channel Number buttons (0-9) | Directly tunes channels. |
| 10 | Channel Number buttons (0-9) | | 11 | (-) button | Enters 2-part channel numbers. |
| 11 | (-) button | | 12 | CH RTN button | Returns to the last viewed channel or source. |
| 12 | CH RTN button | | 13 | INFO button | Displays TV status information as well as program details, when available. |
| 13 | INFO button | | 14 | VOL (+/-) buttons | Adjusts the volume level. |
| 14 | VOL (+/-) buttons | | 15 | CH (▲/▼) buttons | Cycles through programmed channels. |
| 15 | CH (▲/▼) buttons | | 16 | MUTE button | Reduces or turns off the sound. |
| 16 | MUTE button | | 17 | MEDIA SHARE button | Accesses the MEDIA SHARE function. |
| 17 | MEDIA SHARE button | | 18 | SEARCH button | Accesses the SearchAll function. |
| 18 | SEARCH button | | 19 | HOME button | Accesses the CLOUD HOME. |
| 19 | HOME button | | 20 | INTERNET button | Launches the web browser on-screen. |
| 20 | INTERNET button | | | | |